

Date:	
Type:	
Firm Name:	
Project:	



SP-R42

# Spectrum Round Series

Everylite Datasheet Ver 2.1  
Revision Date 12/2019



## Features

- UL, CE and RoHS compliant.
- IP68 and UV resistant with fully integrated molding and lens.
- Fully potted modules to ensure a high-quality waterproofing.
- Utilizes DMX512 protocol for flexibility of control and compatibility.
- SMD3535 LED chips for increased brightness, color consistency, and saturation.
- Constant Current Technology ensures even illumination throughout your project.
- The Spectrum modules integrated DMX decoders eliminate the need for external DMX Decoders.



## Spectrum R42 Series Parameters

Item #	LED Color	Housing Color	Control Mode	Modules/ft	Lm/module	Input Voltage	W/module	Viewing Angle	Waterproof
SP-R42-FXS-G	RGB	Gray	DMX	3	45.25	24	1.5W	120°	IP68
SP-R42-FXS-B	RGB	Black	DMX	3	45.25	24	1.5W	120°	IP68
SP-R42-FWS-G	RGBW	Gray	DMX	3	45.25	24	1.8W	120°	IP68
SP-R42-FWS-B	RGBW	Black	DMX	3	45.25	24	1.8W	120°	IP68

\*Varies based on customization options.

## Power Supply Maximum Loading Capacity\*

1.5 Watt LED

Power Supply	20W	60W	100W	150W	240W
By Module	12 mods	36 mods	60 mods	90 mods	144 mods
By Footage	4 ft	12 ft	20 ft	30 ft	48 ft

1.8 Watt LED

Power Supply	20W	60W	100W	150W	240W
By Module	10 mods	30 mods	50 mods	75 mods	120 mods
By Footage	3.33 ft	10 ft	16.67 ft	25 ft	40 ft

\*Due to voltage drop, a maximum of 50 modules can be run with a single input of power and up to 100 modules can be run with a dual input of power.

## Common Parameters

LED Manufacturer	LED Chip Size	LED Quantity	Rated Lifetime	Working Temperature	Storage Temperature
Epistar/Cree	SMD3535	6-8 pcs	≥30000 hours	-4°F ~ 140°F	-40°F ~ 167°F

## Testing

Power Testing	Drop Test	Thermal Shock	Salt Spray Test	UV Test	ESD Test	IP Rating	Flame Retardance
5V, Ta=77°F ±9°F	48" (10 cycles)	-40°F(30 mins) ~ 212°F(30 mins) 200 cycles	Salt 5% (72 hours)	UV-A, 350-400nm, 140°F (72 hours)	3000V	IP68 20" underwater (48 hours)	UL94-V0 (10 cycles)

## Drawing

Unit: inches

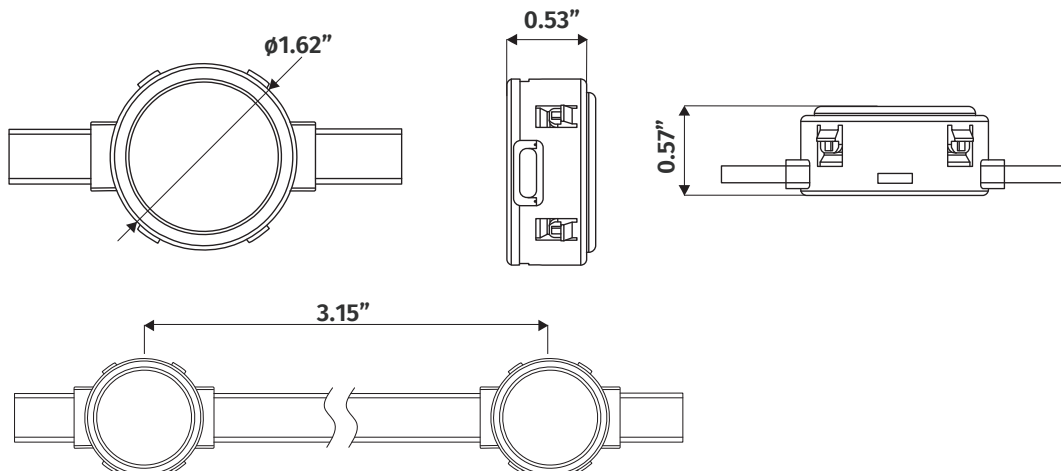

NOTE: The center to center distance shown is the minimum length of the cable, this can be customized.

**Spectrum R42 Series Mounting Clips**

Unit: inches

